

1052-3

MAR 31 1938

# Mercury Light

FOR BETTER SIGHT

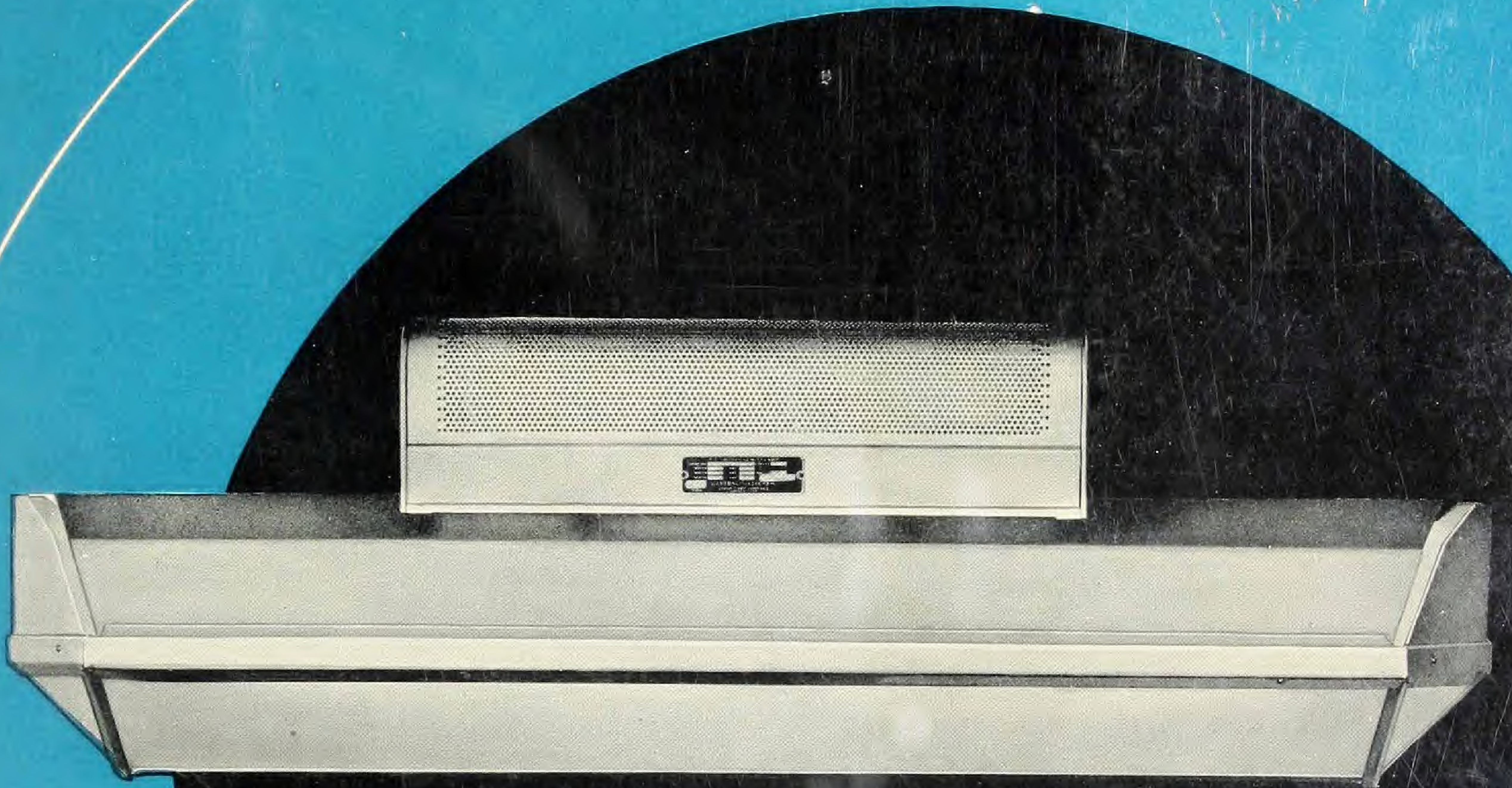

COMBINATION COOPER HEWITT  
INCANDESCENT LAMPS . . . . .

FRANKLIN INSTITUTE  
PHILADELPHIA



# Light.....

## **TO FIT THE JOB!**

Lighting especially engineered to a particular job is the growing practice. It is recognized as the only practical method of assuring the most efficient illumination.

It is no longer satisfactory to rely on lighting levels alone. The quality of the light is today recognized as an extremely important property. Cooper Hewitt Mercury Vapor Light has been the accepted standard of quality in practically every branch of industry for almost thirty years. This detail-revealing light satisfies all requirements where ease of seeing and reduction of eye-fatigue are important.

These new Cooper Hewitt-Incandescent Combination Lamps are intended for those industrial seeing tasks which require not only perception of detail but also of color. These combination lamps retain the visual qualities of the Cooper Hewitt to a great extent and add sufficient incandescent light to permit recognition of colors.





1052-3

The

## "24-HOUR SKYLIGHT"



*Cooper Hewitt-Incandescent Combination Open Type Unit*

### **gives you these benefits**

- 1.** Stimulates quick visual response in all seeing tasks, even to minute detail.
- 2.** Restful and permits continued use of the eyes without fatigue, let-down and possible errors.
- 3.** Good vision at all working points.
- 4.** A quality of light that permits recognition of all colors.
- 5.** A long light source of low intrinsic brilliance which promotes even distribution of light and eliminates troublesome shadows.
- 6.** More light on vertical surfaces.
- 7.** Details visible in recesses, holes and other normally dark places.
- 8.** Safe and comfortable for the workers.
- 9.** Uniformly better quality of work.



# "Daylight....."

## WITH ECONOMY

"Better than daylight" has characterized Cooper Hewitt lighting ever since its inception. In this new unit Cooper Hewitt mercury light and incandescent light are combined. The combination produces a light that closely approximates skylights at their best, and provides it without the inherent variations in intensity such as occur in natural daylight illumination. In grading oranges . . . cutting silk lingerie . . . rolling aluminum . . . inspecting oak flooring . . . decorating chinaware . . . and many other operations . . . combination lighting has proved a boon.

This lighting unit is especially efficient because it combines the violet, blue, green and yellow rays of the Cooper Hewitt mercury lamp with the yellows and reds of incandescent lamps. By so doing it corrects color by addition rather than by subtraction, as is the case when glass filters are used. Filtering out undesirable rays absorbs a high percentage of generated light. For example, to get certain daylight qualities it is necessary to absorb as much as 85% of the light output of an incandescent lamp.

Ordinary skylights have their place in the modern industrial plant. However, it must be borne in mind that dirt and dust and excessive heat losses always





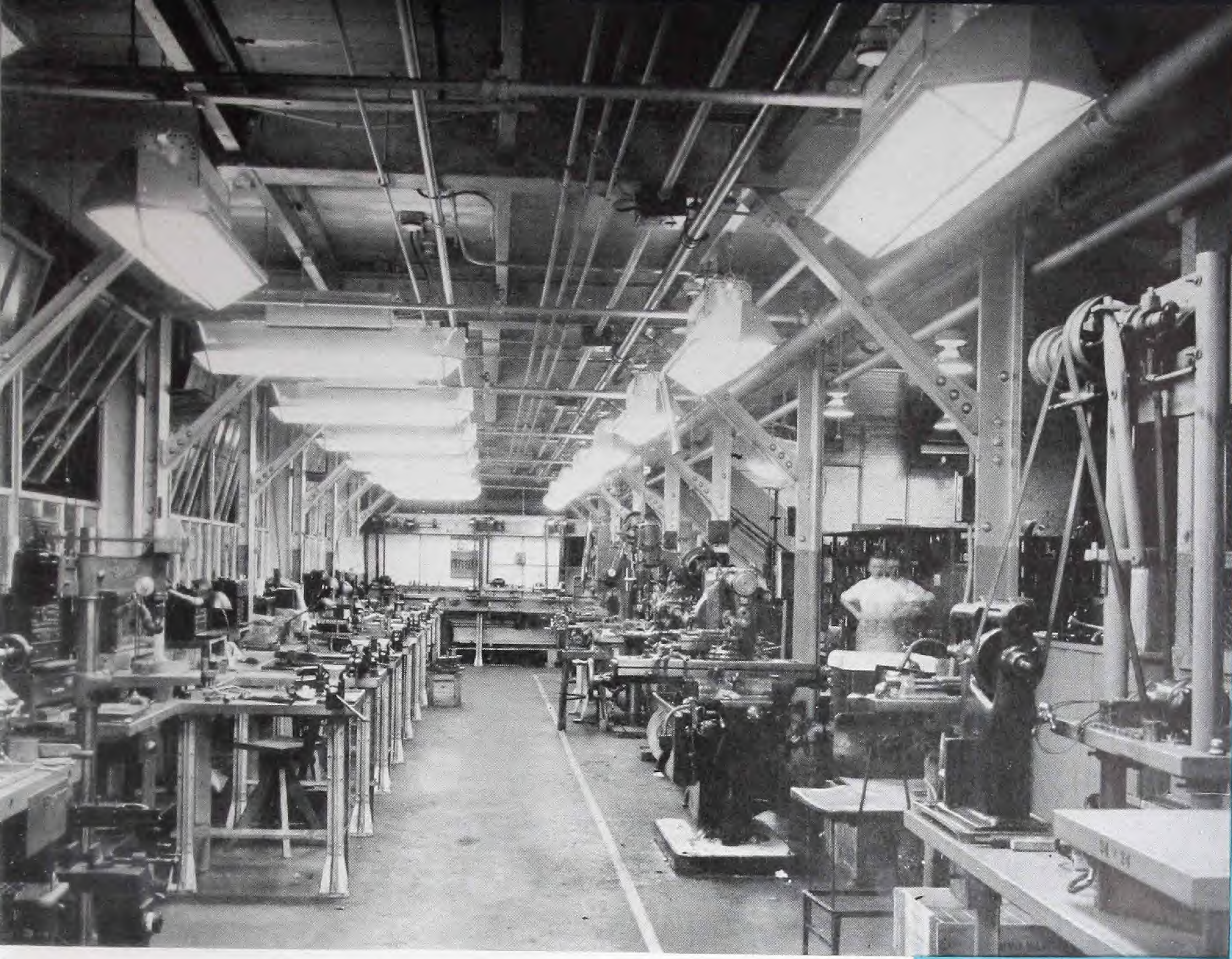

Tool-making section of Warren Telechron Co.—good workmanship is stimulated by over 60 foot-candles of cool, color-balanced light on benches and machines.

diminish the anticipated beneficial effect of a skylight. Moreover, it is effective only on the top story of a plant and the intensity of light cannot be controlled economically. The long light source of the Cooper Hewitt lamp provides an evenly distributed light that eliminates annoying shadows. The addition of incandescent lamps to correct color makes the new Combination Cooper Hewitt unit a more productive and uniform source of illumination than a 5-foot skylight.

The light itself may be color-balanced, so that the change from real daylight to “artificial daylight” is almost unnoticeable. As will be seen from the photographs which follow, the use of this combination light source is finding wide application. It has ended a lot of headaches for lighting engineers as well as for those who work under its soft, detail-revealing light.



Outside weather changes never bother this office. Color-corrected Cooper Hewitt light provides restful seeing for every square foot . . . every hour of the day or night.



## THE "24-HOUR SKYLIGHT" IS SEEN

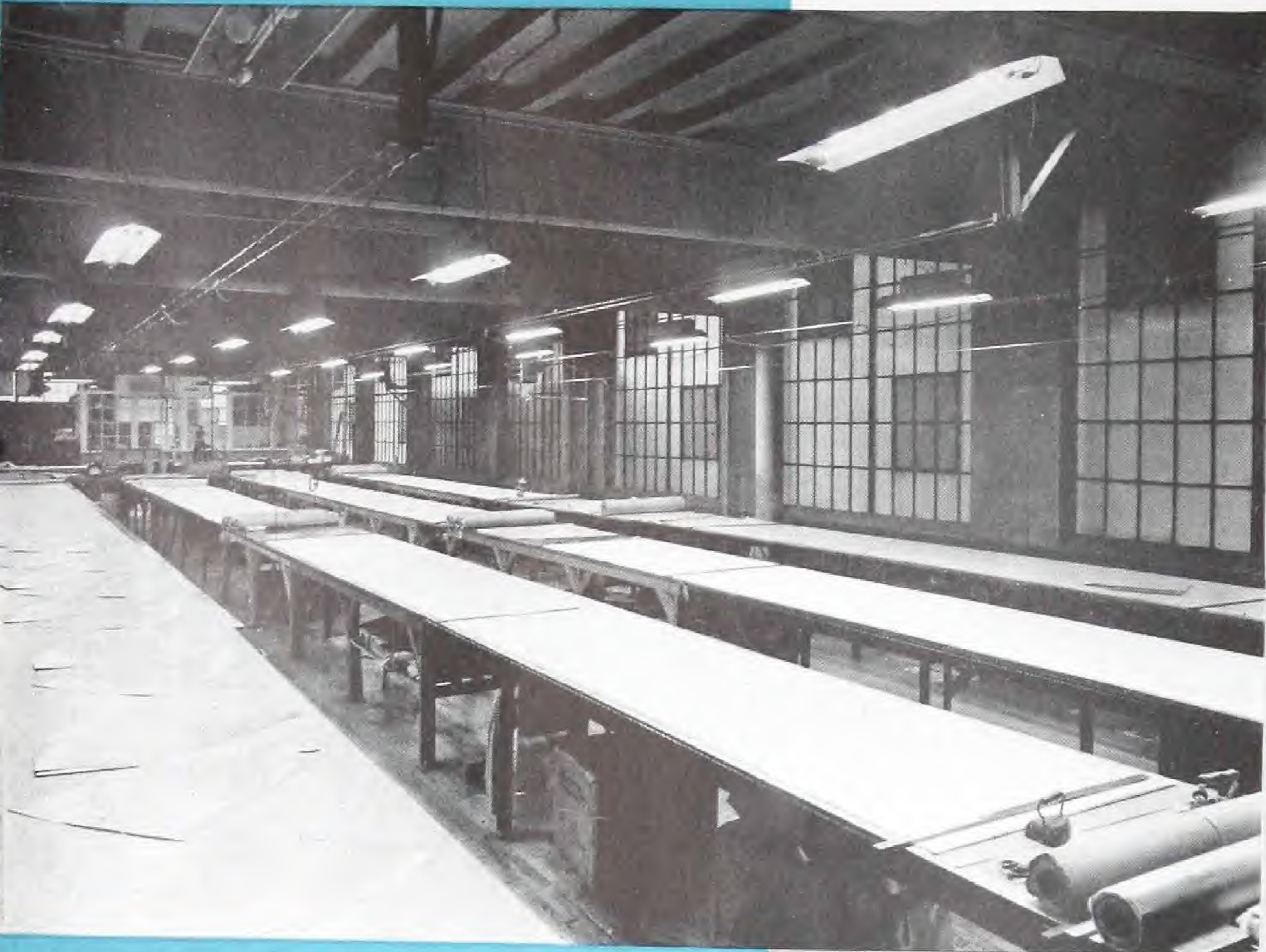

To the left, in the lingerie cutting department of the Real Silk Hosiery Company, *Open Type* Combination Cooper Hewitt-Incandescent Lamps are used. A uniform, detail-revealing light over every square inch of the cutting tables assures accuracy and a minimum of rejects.

To the right, W. H. Hall, Inc., furriers, use Cooper Hewitt-Incandescent Lamps as light sources in special decorative fixtures of modern design. The daylight characteristics of this lighting system bring out the natural beauty of the furs.



To the left, not a spot gets by in this dry cleaning plant where mercury and incandescent light combine to supplement daylight. Spots practically invisible under ordinary light now show up plainly. Workers do a better job — and do it faster — as is the case in all branches of industry where this "synthetic daylight" is used.



# ING EVERY BRANCH OF INDUSTRY

To the right, there is no shadow problem . . . no seeing problem of any kind . . . for this operator. The "skylight" effect of the enclosed mercury-incandescent combination unit provides a diffused light without reflected glare. Eye-strain is banished and safety is promoted.

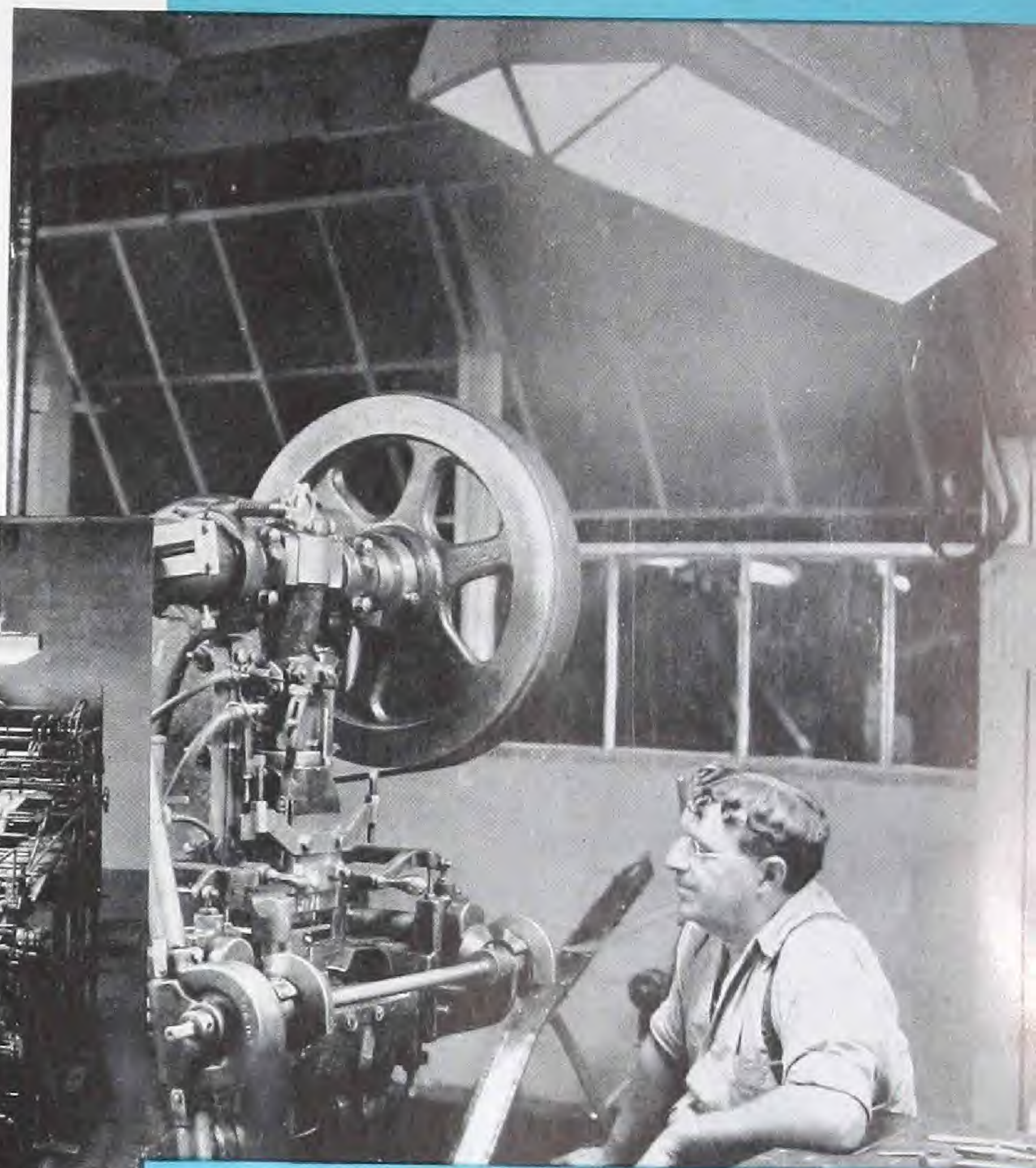

To the left: Three "artificial skylights" precisely located for ideal seeing conditions aid a difficult job of three-color printing on glassine in the windowless plant of the Hershey Chocolate Corporation. More than 75 foot-candles of glareless light show up every detail. Quality printing twenty-four hours a day is made easy.

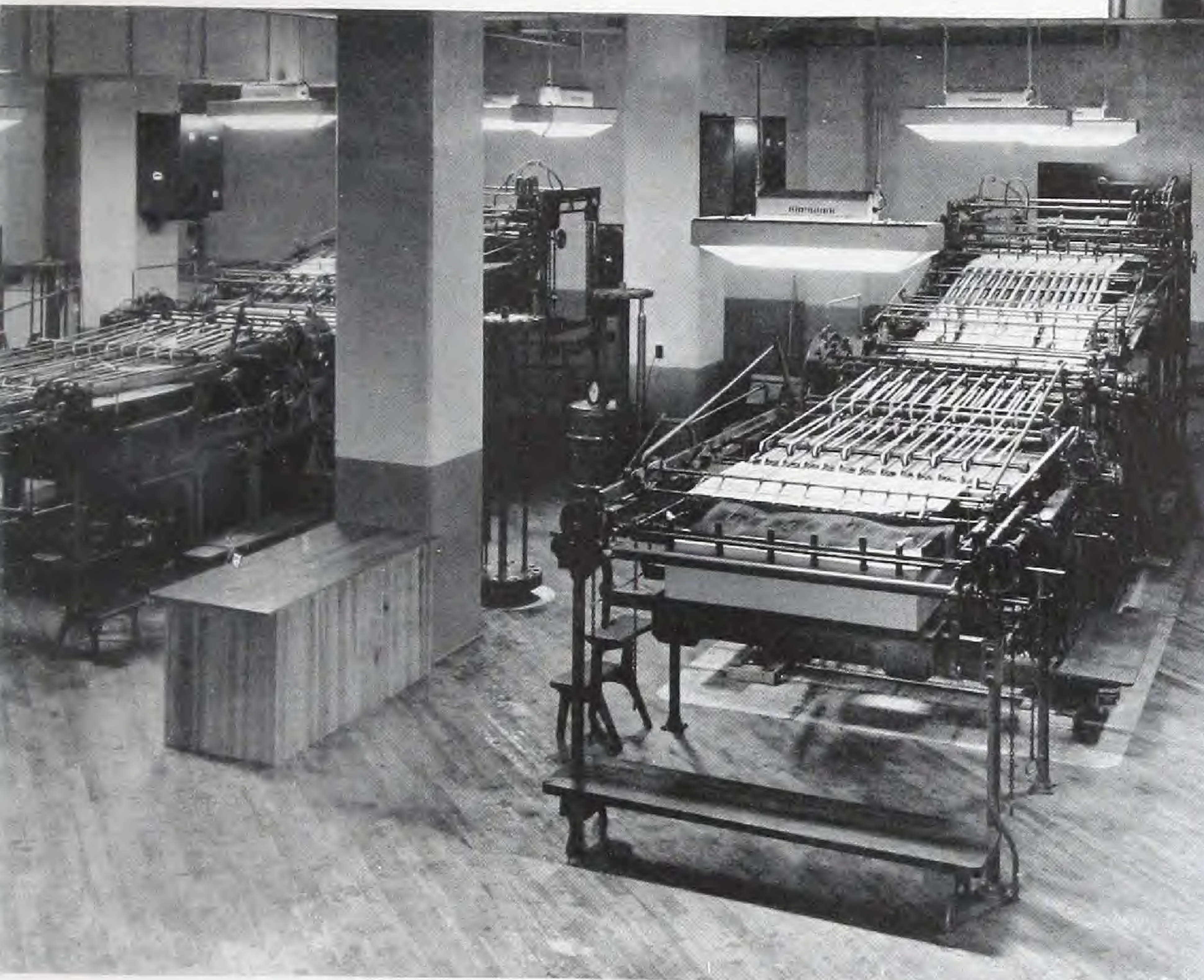

To the right: On this grading table at the Atlanta Oak Flooring Company, Atlanta, Ga., "clear" flooring — which is the highest standard grade — is now readily separated from that showing slight defects. The uniform, detail-revealing mercury-incandescent light has proved "better than daylight" for this work. (Note that the windows have been painted to exclude the annoying variations of outside daylight).







This mill has a reputation for turning out some of the finest cotton rayon and spun rayon fabrics in the South. To safeguard this reputation inspection and shading are now carried out under color-corrected "skylight" units. With 12 x 16 foot center spacings, illumination level exceeds 30 foot-candles. This means that the tiniest of imperfections are quickly seen. The soft diffused light has ended eye-fatigue.

Combination Cooper Hewitt and Incandescent lamps with diffusers provide a light that is just right to reveal all the details so essential to efficient and rapid handling of type. There is no glare and no eye-fatigue here.



About 85% of a draftsman's work, it is estimated, is guided and directed by his sight. He needs a soft, shadowless light evenly distributed over the entire drawing board. He needs a form of lighting that does not require continual manual adjustment to avoid spots of glare over the tracing cloth. Such a light is provided by the new mercury-incandescent "skylight" unit. Here at Curtiss-Wright the large floor area, in the foreground, is used for full-scale airplane tracings.



Simplicity and convenience feature every detail of these new Combination Cooper Hewitt Incandescent light units . . . quick starting is provided by an entirely new principle of operation.

Note, in the illustration at the right, the ease with which lamps can be adjusted to prevailing line voltage through the use of a moulded plug in a three-position convenience outlet. The voltages are clearly shown. Tap connections are easily seen from the floor at all times.

Below is a cutaway view which clearly illustrates the placing of the incandescent lamps with relation to the Cooper Hewitt tube — in a position as to assure the maximum efficiency of the reflector.

Units are designed to operate with incandescent lamps from 50 watts to 150 watts per socket. This range in design permits a wide choice for the user in the degree of color balance he may obtain.

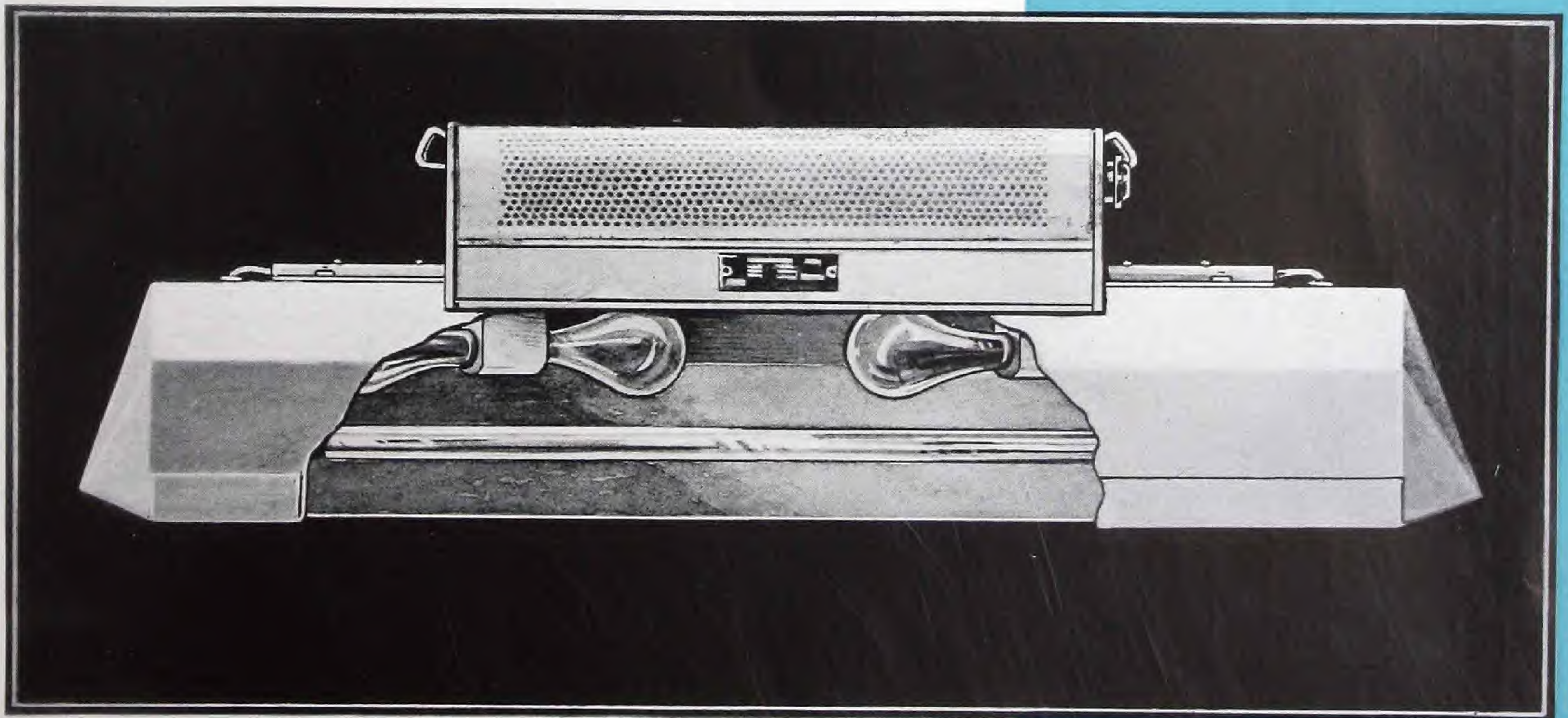
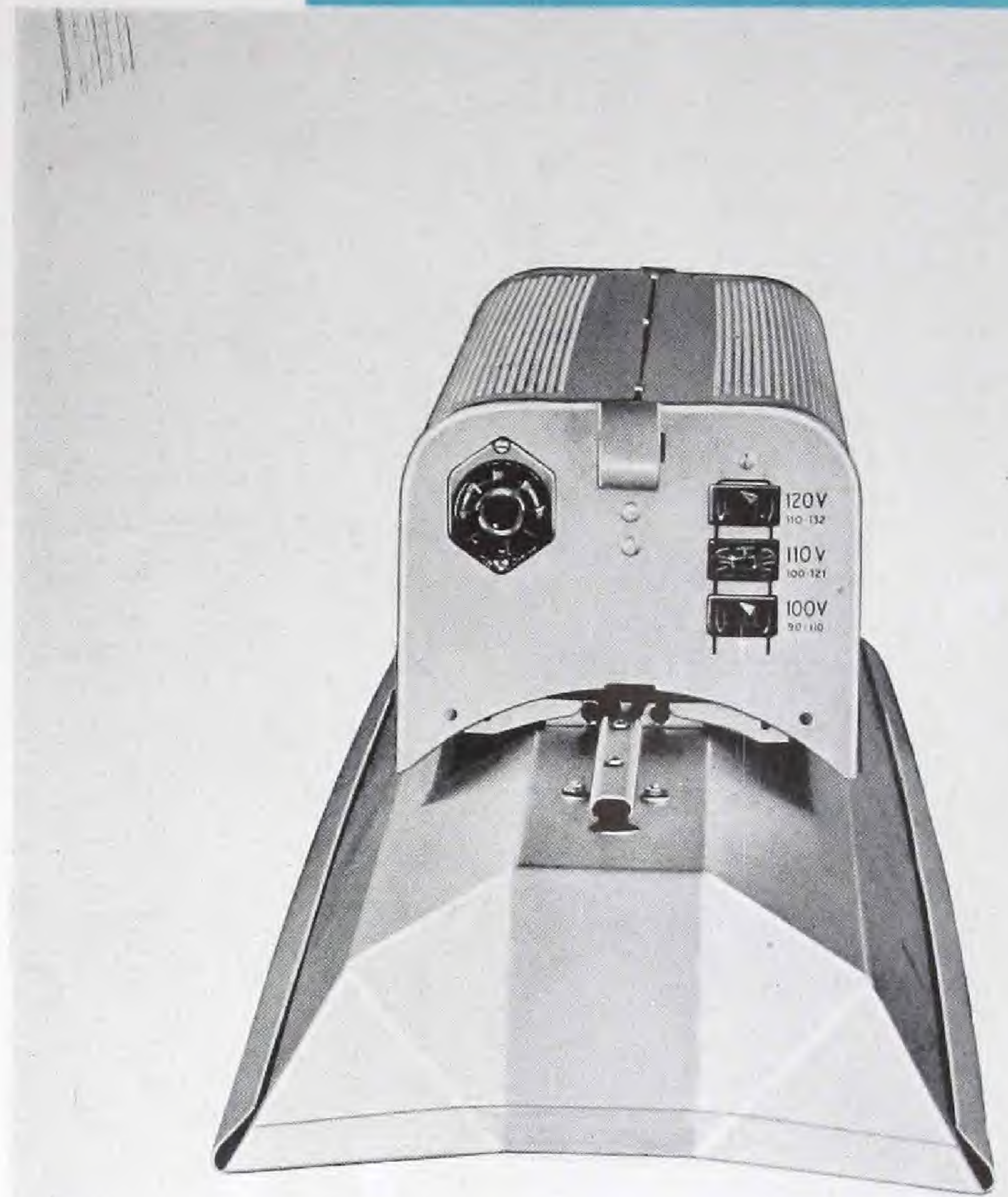



# ENGINEERING DATA

FOR THE NEW  
(High Power Factor)  
COMBINATION  
COOPER HEWITT  
INCANDESCENT LAMP  
(DIFFUSER UNIT)

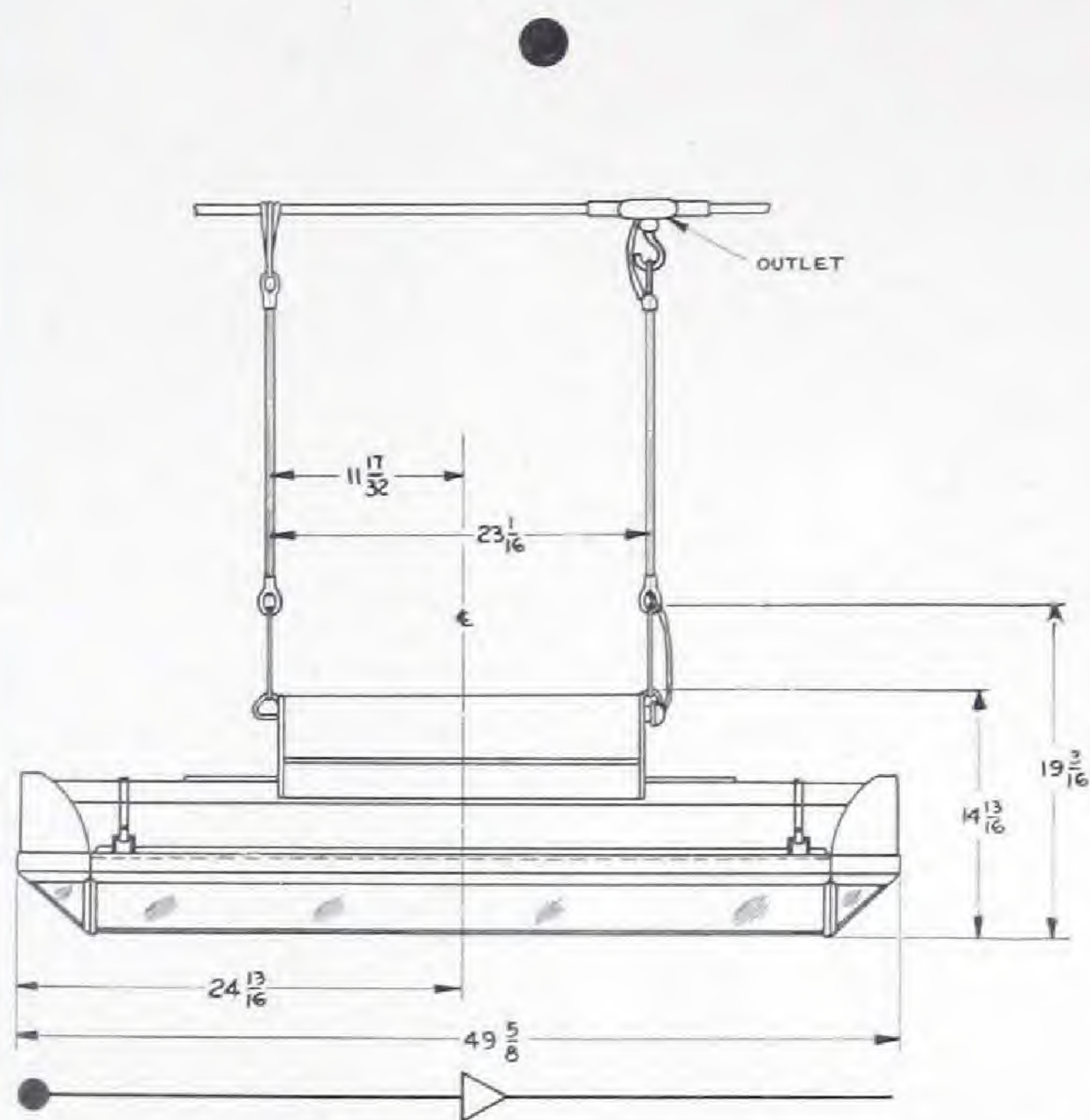

LAMP SYMBOL FOR LIGHTING LAYOUTS  
Essential dimensions and method of lamp suspension

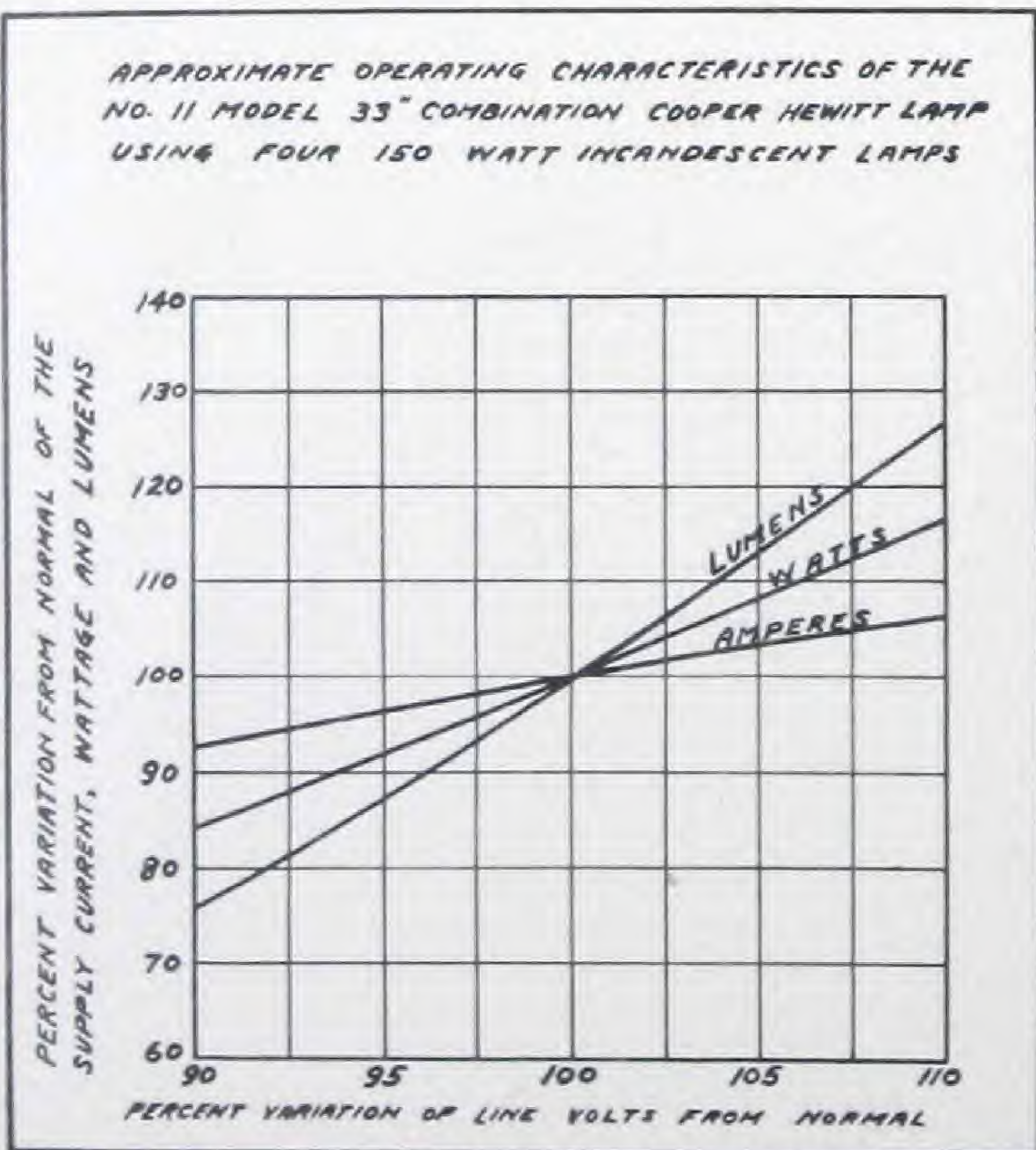

Operating characteristics of alternating current lamp unit

## PHOTOMETRIC RATING

Alternating Current Combination Cooper Hewitt-Incandescent Lamp Equipped with Standard Alzak Aluminum Reflector and Frosted Glass Diffuser

### INITIAL OUTPUT

	275-Watts Mercury		
	300-W	400-W	600-W
Cooper Hewitt Tube.....	575	675	875
Four Mazda Lamps.....	9090	11040	15120
Total Watts per Unit.....	4680	5600	7450
Total Bare Lamp Lumens.....	4452	5332	7116
Total Overall Lumens (0-180).....	51%	51%	49%
Total Downward Lumens (0-90).....	15.8	16.4	17.3
Fixture Efficiency (overall).....	8.15	8.3	8.5
Lumens per watt (Bare Lamp).....	7.75	7.9	8.1
Lumens per watt (overall).....			
Lumens per watt (downward).....			

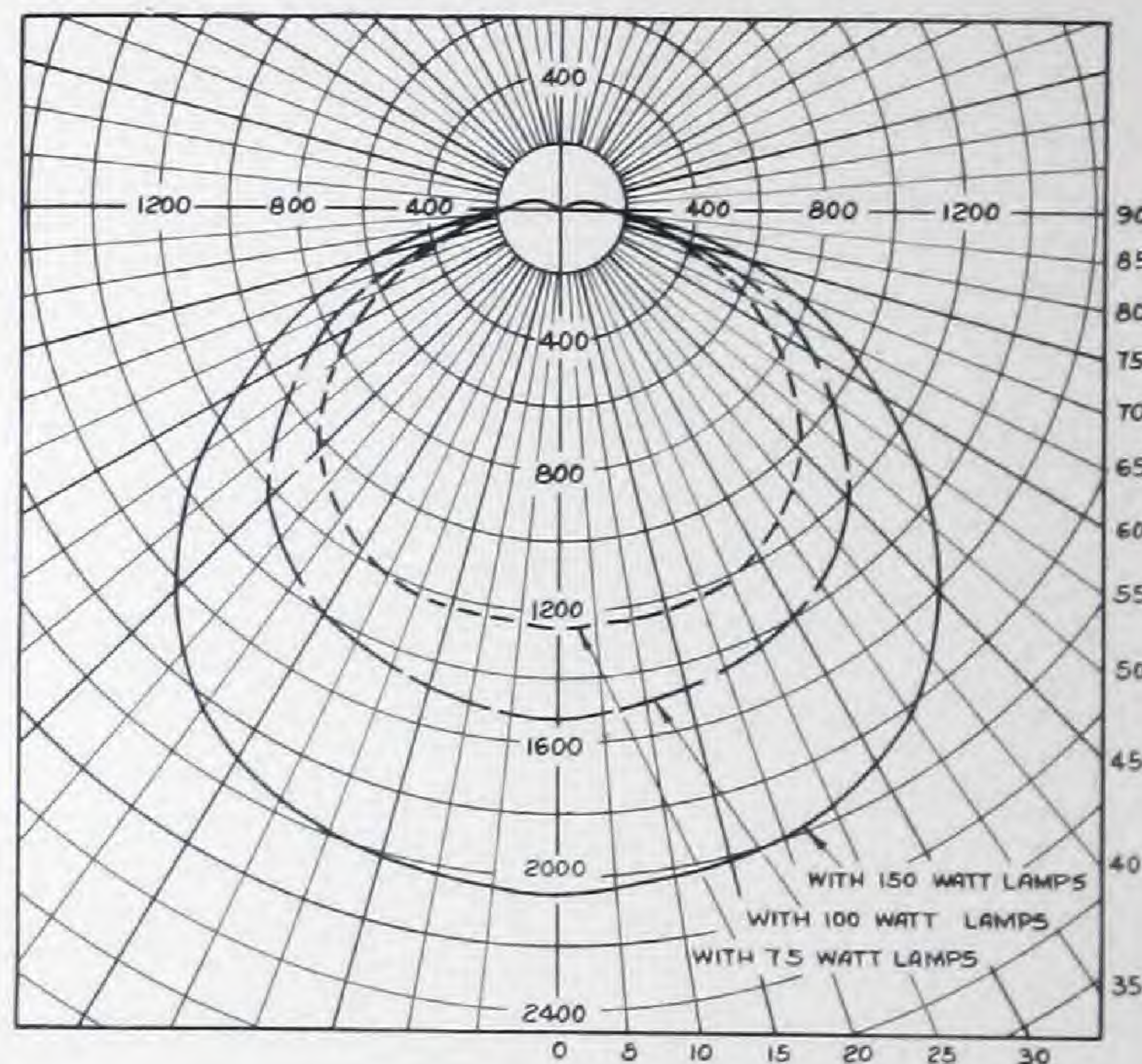
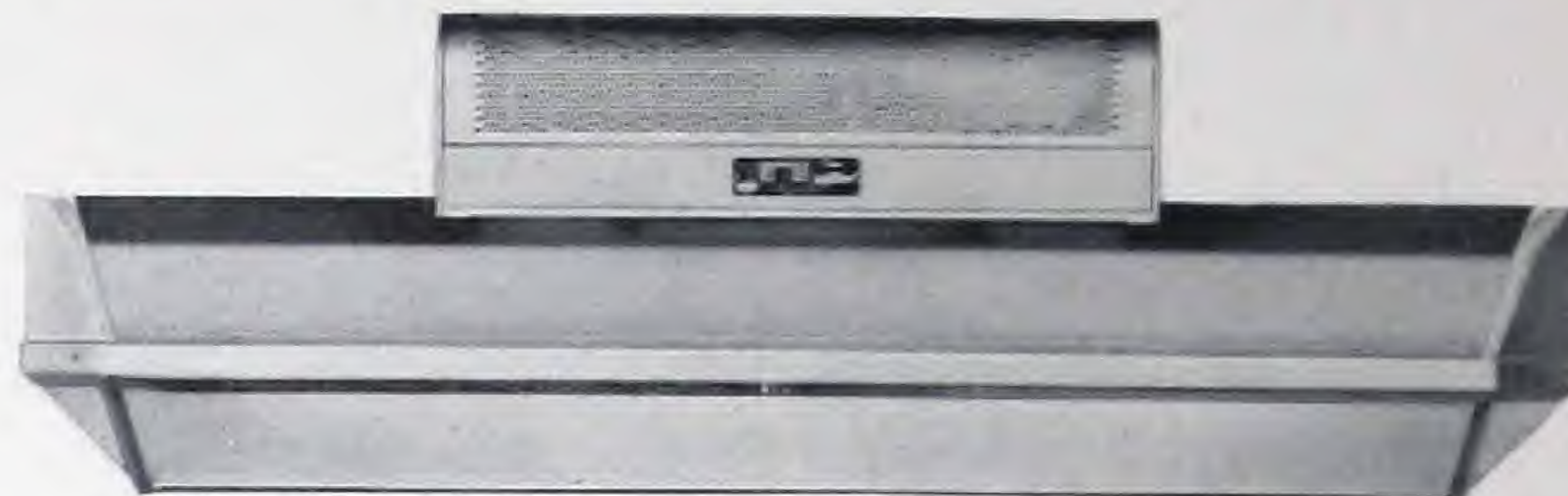

Mtg. Ht. Above Working Plane (Feet)	Foot Candles Directly Under One Lamp	Average foot-candles produced by sixteen 875 watt (diffuser) combination Cooper Hewitt lamps symmetrically spaced															
		Horizontal Distance Between Lamps (Feet)															
		6	7	8	9	10	11	12	13	14	15	16	18	20	25		
6	57.4	161.9	120.2	90.6	69.8	53.5	41.9	33.2	26.4	21.1	17.3	14.1	9.3	6.6	3.1		
7	42.2	154.5	117.4	91.7	72.6	56.7	45.4	36.7	29.7	24.3	19.8	16.3	11.3	8.3	3.8		
8	32.3	145.3	113.3	90.5	72.3	58.7	47.3	39.2	32.3	26.9	22.3	18.5	13.2	9.7	4.7		
9	25.5	135.5	107.7	87.5	71.5	58.4	48.4	40.1	33.8	28.3	23.9	20.3	14.7	10.9	5.5		
10	20.7	126.3	102.1	84.0	69.6	57.4	48.2	40.4	34.6	29.4	25.1	21.5	15.9	12.0	6.2		
12	14.3	108.5	90.2	76.0	64.4	54.5	46.7	39.9	34.6	30.0	26.1	22.8	17.4	13.6	7.4		
14	10.5	92.9	79.5	67.8	58.6	50.3	43.8	38.1	33.4	29.3	25.6	23.0	18.0	14.2	8.2		
16	8.1	79.9	69.6	60.9	53.4	46.5	41.2	36.1	32.1	28.3	25.3	22.5	18.1	14.8	8.9		
18	6.4	68.7	61.2	54.3	47.9	42.7	38.0	33.6	30.2	27.0	24.3	22.1	17.7	14.6	9.2		
20	5.2	59.4	52.9	48.4	42.9	38.9	35.2	31.3	28.5	25.6	22.9	20.7	17.4	14.4	9.5		
25	3.3	42.2	39.4	36.5	33.7	31.0	28.6	26.1	24.0	21.9	20.0	18.4	15.8	13.4	9.3		

NOTE: Multiply foot-candles in table by factors shown below for different size Mazda lamps:  
150-watt ..... 1.00  
100-watt ..... 0.75  
75-watt ..... 0.60

### Approximate Watts per Square Foot of Horizontal Surface

24.3	17.9	13.7	10.8	8.8	7.2	6.1	5.2	4.5	3.9	3.4	2.7	2.2	1.4
------	------	------	------	-----	-----	-----	-----	-----	-----	-----	-----	-----	-----

### GENERAL SPECIFICATIONS

Code No.—Standard Unit—Diffuser Model.....	160H11WL21	260H11WL21
Voltage Range.....	90-100-110 100-110-121 110-120-132	180-200-220 200-220-242 220-240-264
*Average Line Current—Using Four:		
75-watt Mazda Lamps.....	5.5	2.75
100-watt Mazda Lamps.....	6.25	3.15
150-watt Mazda Lamps.....	8.05	4.05
Power Factor—Mercury Lamp only.....	88%	88%
Power Factor—Using Four:		
75-watt Mazda Lamps.....	96%	96%
100-watt Mazda Lamps.....	98%	98%
150-watt Mazda Lamps.....	99%	99%
Mercury Tube—diameter 1 inch.....	33 in. long	33 in. long
Frequency.....	60 cycle only	60 cycle only

\*Average starting currents are approx. 0.4 amp. higher than operating currents for 110-volt lamps and 0.2 amps. for 220-volt lamp.



# ENGINEERING DATA

FOR THE NEW  
(High Power Factor)  
**COMBINATION  
COOPER HEWITT  
INCANDESCENT LAMP**  
(OPEN TYPE)

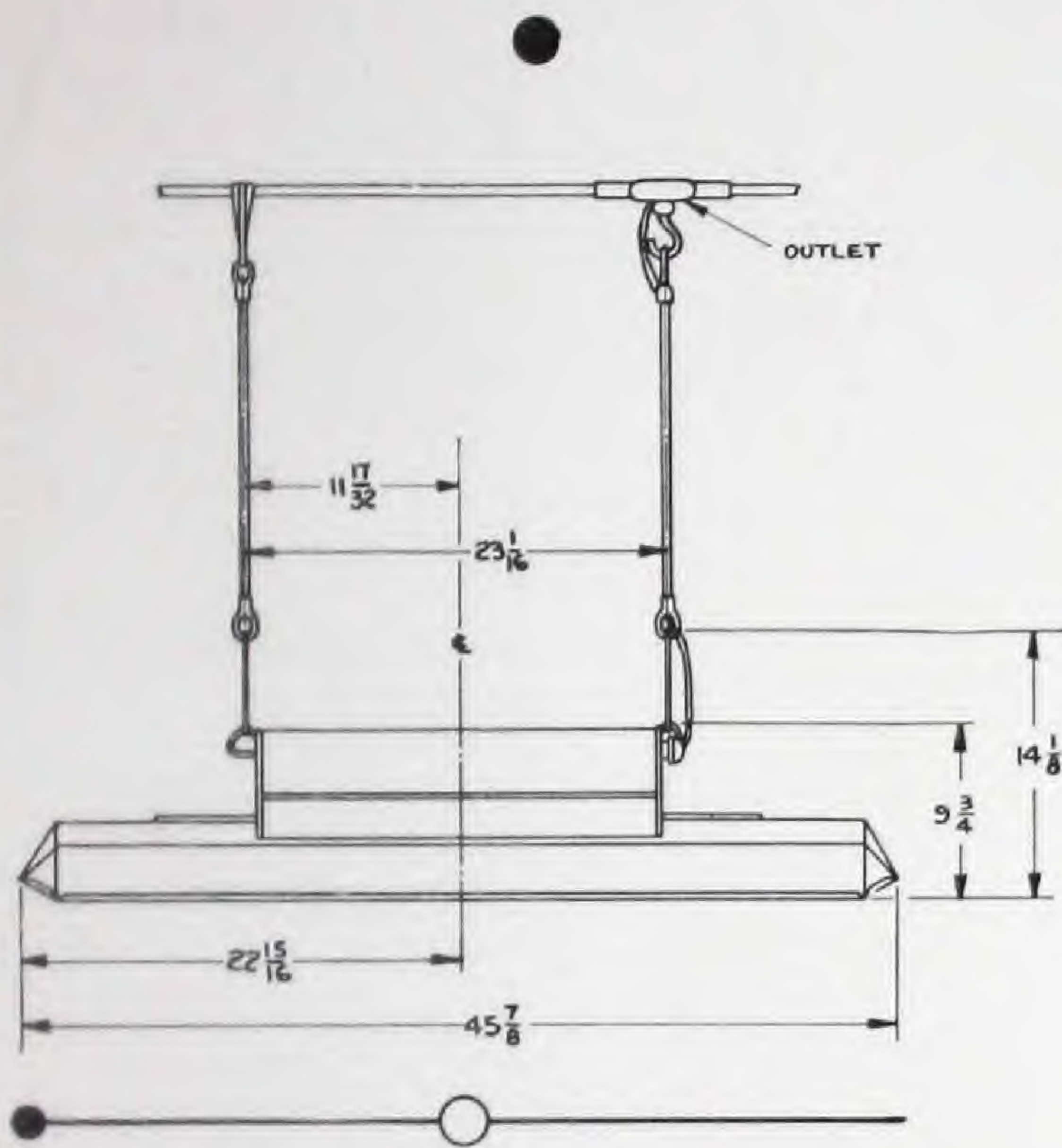

LAMP SYMBOL FOR LIGHTING LAYOUTS

Essential dimensions and method of lamp suspension

**PHOTOMETRIC RATING**  
Alternating Current Combination Cooper Hewitt-Incandescent Lamp  
Equipped with Standard Porcelain Enamelled Reflector

**INITIAL OUTPUT**

Cooper Hewitt Tube.....	275-Watts Mercury		
Four Mazda Lamps.....	300-W	400-W	600-W
Total Watts per Unit.....	575	675	875
Total Bare Lamp Lumens.....	9090	11040	15120
Total Downward Lumens (0-90).....	6800	8368	11200
Reflector Efficiency (0-90).....	75.0%	76.0%	74.0%
Lumens per watt (Bare Lamp).....	15.8	16.4	17.3
Lumens per watt (Downward).....	11.8	12.4	12.8

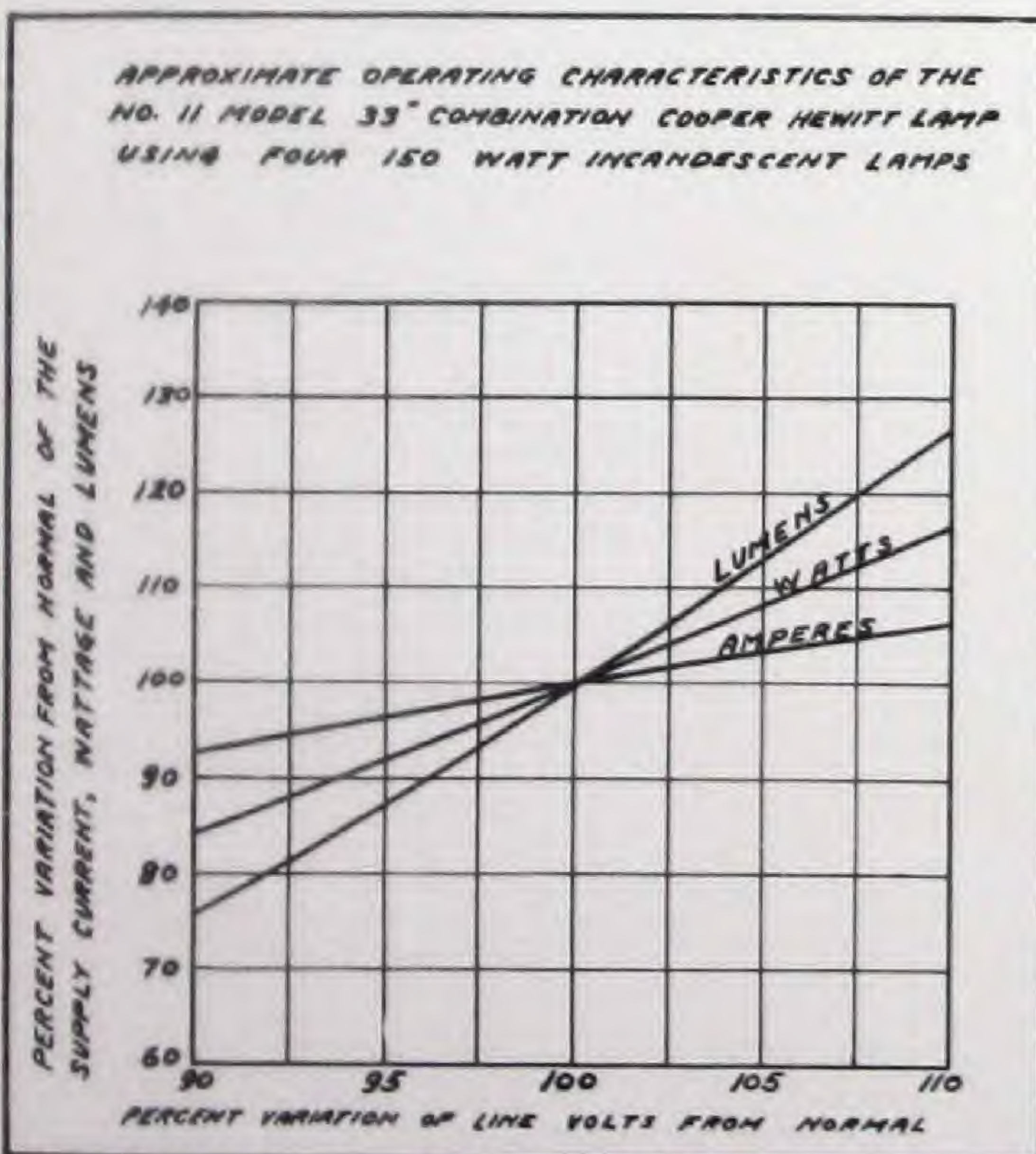
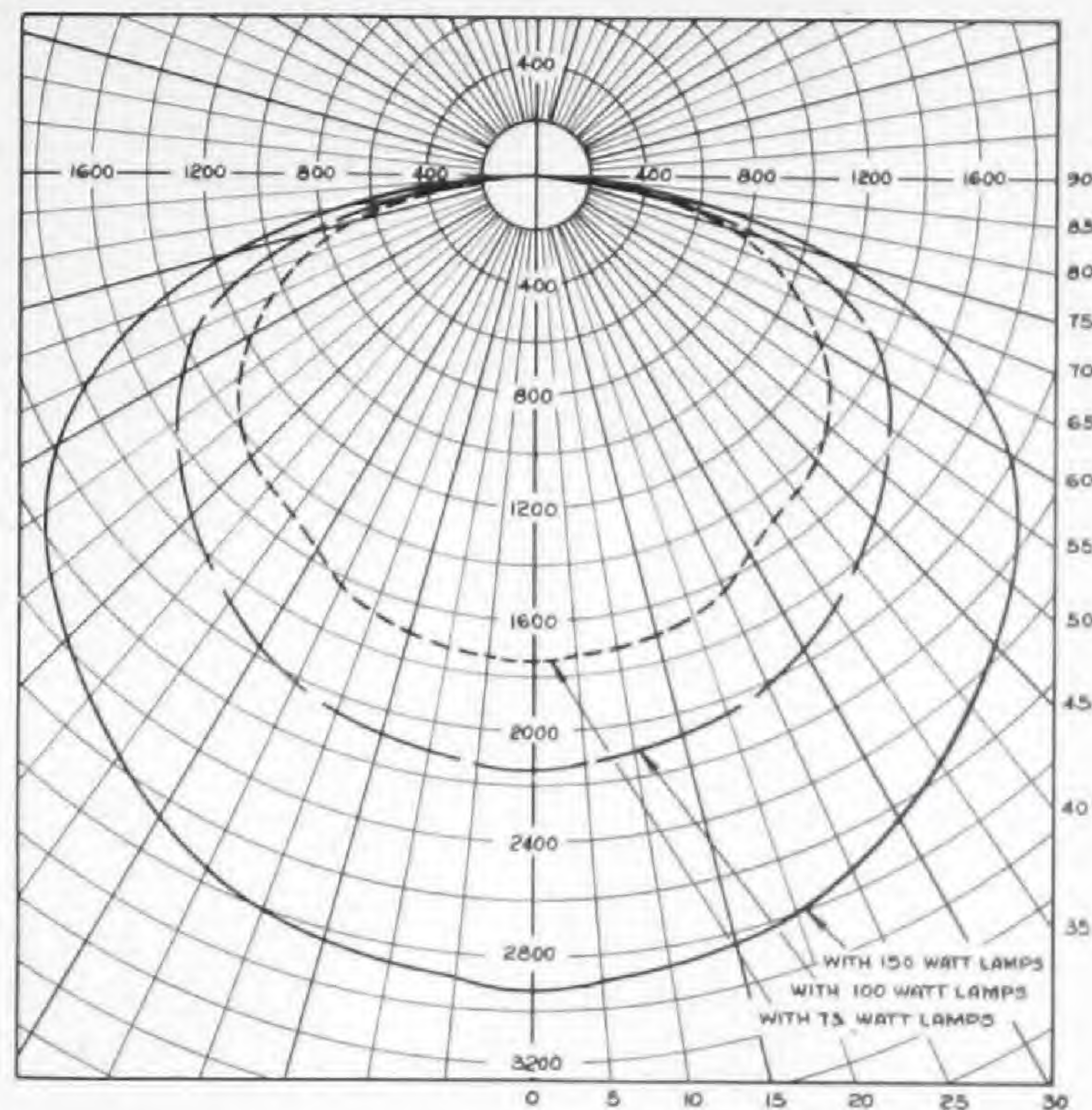

Operating characteristics of alternating current lamp unit

Mtg. Ht. Above Working Plane (Feet)	Foot Candles Directly Under One Lamp	Average foot-candles produced by sixteen 875 watt combination (open type) Cooper Hewitt lamps symmetrically spaced													
		Horizontal Distance Between Lamps (Feet)													
		6	7	8	9	10	11	12	13	14	15	16	18	20	25
6	81.5	243.8	183.6	141.7	109.7	86.3	68.9	55.7	45.1	36.9	30.6	25.5	17.5	12.5	5.9
7	60.0	228.7	177.0	140.1	112.5	89.5	72.6	60.0	49.0	40.9	34.1	28.4	20.5	15.2	7.2
8	45.9	213.1	168.4	136.0	110.1	90.6	74.0	62.1	51.9	43.8	36.9	31.3	22.8	17.1	8.8
9	36.3	197.3	158.5	130.5	107.7	88.9	74.5	62.6	53.2	45.4	38.7	33.3	24.6	18.9	10.1
10	29.4	182.2	149.0	123.6	103.4	86.6	73.3	62.3	53.7	46.0	39.8	34.5	25.9	20.0	10.9
12	20.4	154.3	129.8	110.5	94.4	80.5	69.6	60.2	52.6	46.0	40.3	35.5	27.7	21.8	12.6
14	15.0	131.4	113.3	97.6	85.0	73.8	64.4	56.6	50.0	44.3	38.9	35.0	27.9	22.5	13.4
16	11.5	111.9	98.2	86.7	76.5	67.3	59.9	53.1	47.3	42.1	37.9	33.9	27.6	22.8	14.2
18	9.1	96.1	86.1	76.6	68.3	61.3	54.8	48.9	44.1	39.9	35.9	32.7	26.7	22.3	14.4
20	7.3	82.9	74.1	68.0	60.7	55.5	50.4	45.2	41.2	37.2	33.6	30.5	25.7	21.6	14.5
25	4.7	59.2	55.1	51.3	47.3	43.5	40.2	37.0	34.2	31.4	28.9	26.7	23.1	19.8	14.1

NOTE: Multiply foot-candles in table by factors shown below for different size Mazda lamps:  
150-watt ..... 1.00  
100-watt ..... 0.75  
75-watt ..... 0.60

Approximate Watts per Square Foot of Horizontal Surface														
6	7	8	9	10	11	12	13	14	15	16	18	20	25	
24.3	17.9	13.7	10.8	8.8	7.2	6.1	5.2	4.5	3.9	3.4	2.7	2.2	1.4	

**GENERAL SPECIFICATIONS**

Code No.—Standard Unit—Open Type Model.....	160H11W L19	260H11W L19
Voltage Range.....	90-100-110 100-110-121 110-120-132	180-200-220 200-220-242 220-240-264
*Average Line Current—Using Four:		
75-watt Mazda Lamps.....	5.5	2.75
100-watt Mazda Lamps.....	6.25	3.15
150-watt Mazda Lamps.....	8.05	4.05
Power Factor—Mercury Lamp only.....	88%	88%
Power Factor—Using Four:		
75-watt Mazda Lamps.....	96%	96%
100-watt Mazda Lamps.....	98%	98%
150-watt Mazda Lamps.....	99%	99%
Mercury Tube—diameter 1 inch.....	33 in. long	33 in. long
Frequency.....	60 cycle only	60 cycle only

\*Average starting currents are approx. 9.4 amp. higher than operating currents for 110-volt lamps and 9.2 amp. for 220-volt lamps.



# GENERAL ELECTRIC VAPOR LAMP COMPANY

## *PRODUCTS*

COOPER HEWITT LAMPS

COMBINATION COOPER HEWITT AND MAZDA LAMPS

TYPE H MERCURY LAMPS

UVIARC (ULTRA-VIOLET) LAMPS

NICO LAMPS FOR FLUORESCENT LIGHTING

NEON GLOW LAMPS

KON-NEC-TORS — MERCURY SWITCHES



## *ADDRESS*

HOBOKEN, NEW JERSEY, U.S.A.

### *Branch Offices*

ATLANTA, GA.: 187 Spring St., N. W.

BOSTON, MASS.: 250 Stuart St.

CHARLOTTE, N. C.: 200 S. Tryon St.

CHICAGO, ILL.: 37 West Van Buren St.

CINCINNATI, OHIO: 107 East Fourth St.

CLEVELAND, OHIO: 1365 Ontario St.

DETROIT, MICH.: 3044 West Grand Blvd.

HOLLYWOOD, CALIF.

Keese Engineering Co., 7380 Santa Monica Blvd.

PHILADELPHIA, PA.: 424 Chestnut St.

PITTSBURGH, PA.: 307 Fifth Ave.

ROCHESTER, N. Y.: 183 Main St., East

SAN FRANCISCO, CALIF.

Keese Engineering Co., 557 Market St.

ST. LOUIS, MO.: 611 Olive St.